

Micro Diameter

Type No. 型號	D	L	C	Collet
BT30-KCH20-80	6-20	80	54	SC20
BT40-KCH20-80	6-20	80	54	SC20
BT40-KCH20-105	6-20	105	54	SC20
BT40-KCH20-135	6-20	135	54	SC20
BT40-KCH32-105	6-32	105	68	SC32
BT50-KCH20-105	6-20	105	54	SC20
BT50-KCH20-135	6-20	135	54	SC20
BT50-KCH20-165	6-20	165	54	SC20
BT50-KCH32-105	6-32	105	68	SC32
BT50-KCH32-135	6-32	135	68	SC32
BT50-KCH32-165	6-32	165	68	SC32
BT50-KCH32-200	6-32	200	68	SC32
BT50-KCH42-105	6-42	105	87	SC42

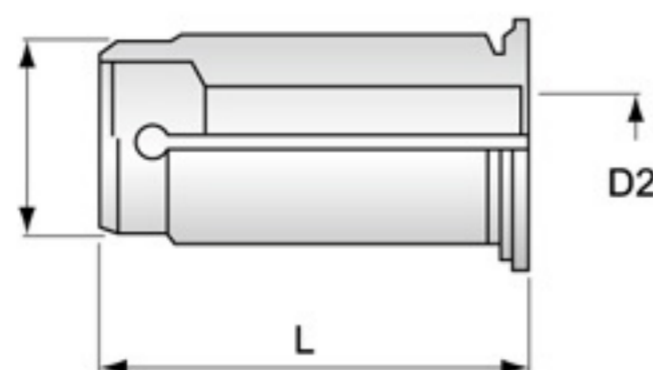

SC筒夾 SC Spring Collets

Type No. 型號	Collet	Model
SC20	6, 8, 10, 12, 14, 16	64
SC32	6, 8, 10, 12, 16, 20, 25	71
SC42	6, 8, 10, 12, 16, 20, 25, 32	80

扳手 Wrench For ASC Milling Chuck W20, W32, W42

Type No. 型號	D1	Chuck
W20	45	ASC20
W32	76	ASC32
W42	76	ASC42